

Merlin Major 21

Car Showroom Turntable

The Merlin Major 21 revolving car turntable platform is virtually invisible in operation, allowing vehicles to be rotated as if by magic. Used across the World by major car manufacturers in car showrooms, exhibitions and product launches, the Merlin Major 21 combines eye-catching movement with ease of installation.



Designed to rotate the majority of contemporary vehicles, the revolve is ideal for turning both smaller family sized saloons and larger prestige marques up to 2,500kg in weight. This flexibility ensures that a full vehicle stock can be rotated, enabling attractive yet cost-effective displays to be created.

Totally portable and requiring no floor fixing, the robust, compact, versatile and extremely smooth running Merlin Major 21 can even be used outdoors, operating from the car's own 12 volt battery, opening it up for forecourt use, launch events, special vehicle brand displays or promotions at the local shopping mall.

Like revolving stage turntables, the Merlin Major 21 features 5 amp slip rings to provide an electrical connection to the rotating element, thereby enabling further lighting and other special effects to be used.

Buy online from our secure online shop:
www.movetechukshop.co.uk



Visit our website for more information:
www.movetechuk.com

Scan QR code or visit our **YouTube** channel to watch a wide range of product videos:
www.youtube.com/MovetechUK



Merlin Major 21

Car Showroom Turntable

Specifications

| | |
|---|------------------------------|
| Capacity: | 2500kg vehicle |
| Maximum Wheelbase: | 3353mm |
| Minimum Wheelbase: | 1905mm |
| Maximum Track: | 1575mm |
| Minimum Track: | 1194mm |
| Base Diameter: | 1000mm |
| Power Consumption (without slip rings): | 30W |
| Fuse Rating: | 5A |
| Shipping Weight: | 323kg |
| Shipping Pack Size (LxWxH): | 2280x1170x400mm |
| Power Requirements: | 220/240v, AC 50/60 Hz. Ph. 1 |
| Power Alternative: | 110v, AC 50/60 Hz. Ph. 1 |
| Power Option: | 12v, DC (Battery) |
| Mains Lead: | 6m, 3-core flex |
| Slip Ring Capacity: | 5A 220/240v AC Ph. 1 |
| Finish: | Gloss Black |
| Speed: | Nominal 0.425 RPM |



- Safety is paramount, which is why the turntable has been designed to stop upon the slightest obstruction.
- The Merlin Major 21 has been designed to be used either internally or externally.
- Visit our YouTube channel to watch a step by step assembly video of the Merlin Major 21.

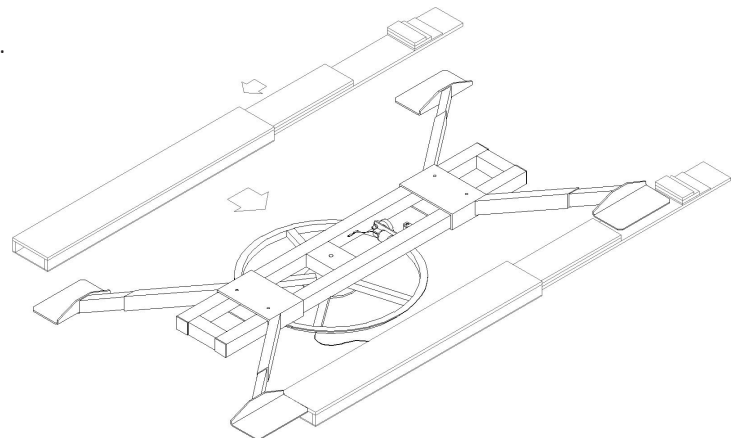

Need help and advice? Telephone: 01204 525626